

PAINTING DETAILS / DÉTAILS DE PEINTURE

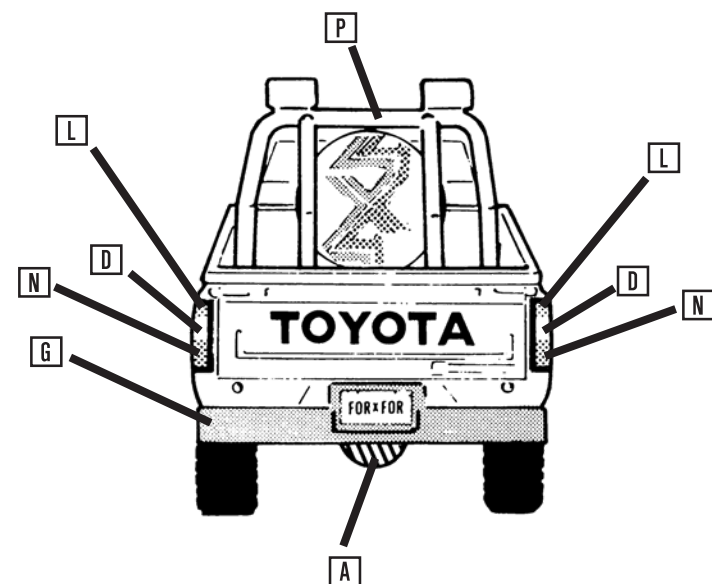
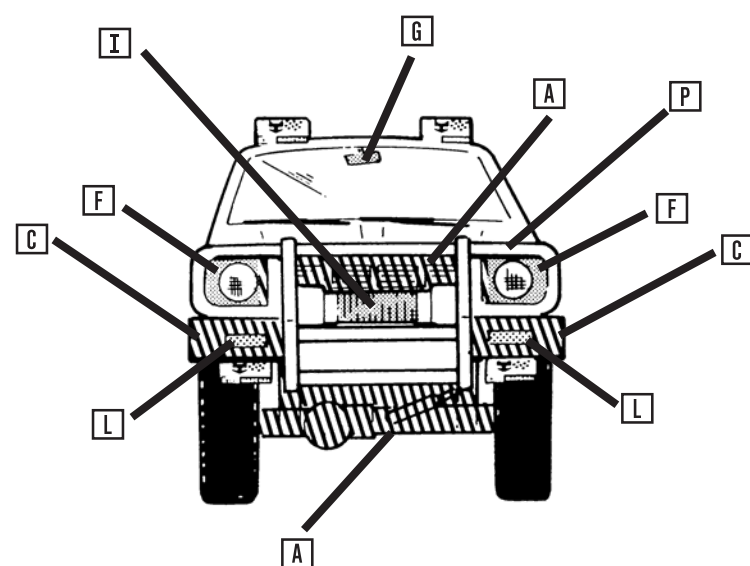
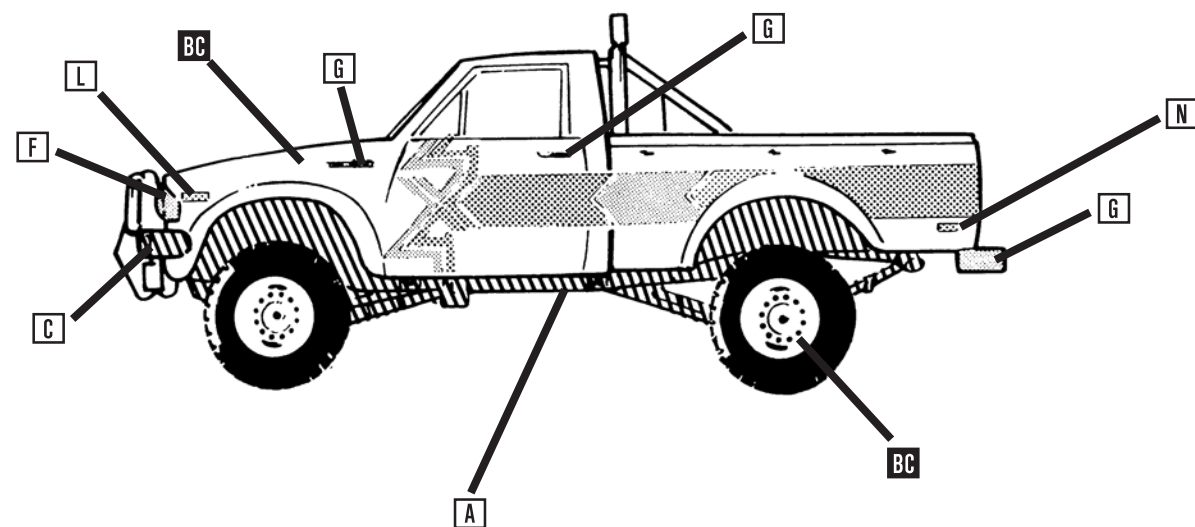

TOYOTA 4x4

1:25 SCALE / ÉCHELLE

A1114M-200

READ THIS BEFORE YOU BEGIN

This kit can be assembled by snapping together the parts as indicated by the instructions. However, if you wish to glue the pieces in a conventional manner, and detail the kit with paints, that is also an easy task.

Before you begin to assemble your model kit, study the instructions carefully. This will help you to familiarize yourself with the part locations as you proceed. Prior to cementing

parts together, be sure to "TEST FIT" them in order to assure proper alignment and also to check for excess "FLASH" that may occur along parting lines. Use a sharp hobby knife or file to remove flash if necessary. This model kit is molded from the finest high-impact styrene plastic. Because the cement will only adhere to bare plastic, it is necessary to remove any paint or "plating" from the area to which the cement is to be applied. Use only cement and paint made for styrene plastic.

LISEZ CECI AVANT DE COMMENCER

Ce kit peut être assemblé en cliquant ensemble les pièces comme indiqué par les instructions. Cependant, si vous souhaitez coller les pièces de manière conventionnelle et détailler le kit avec des peintures, c'est aussi une tâche facile.

Avant de commencer à assembler votre kit de modèle, étudiez attentivement les instructions. Cela vous aidera à vous familiariser avec les emplacements des pièces au fur et à mesure de votre progression. Avant de coller les pièces ensemble, assurez-vous de les

«ASSEMBLER» pour assurer un alignement correct et aussi pour vérifier l'excès de «FLASH» qui peut se produire le long des lignes de séparation. Utilisez un couteau ou un fichier hobby pointu pour enlever le flash si nécessaire. Ce kit de modèle est moulé à partir du plastique de styrène à haute impression le plus fin. Parce que le ciment n'adhère que sur du plastique nu, il est nécessaire d'enlever toute peinture ou "placage" de la zone sur laquelle le ciment doit être appliqué. Utilisez uniquement du ciment et de la peinture pour le plastique styrène.

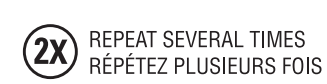
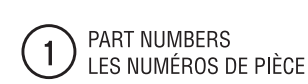
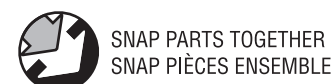

PAINT COLORS / COULEURS DE PEINTURE

A	Black / Noir
B	Flat Black / Noir Mat
C	Semi-Gloss Black / Noir Semi-Glacé
D	White / Blanc
E	Flat White / Blanc Mat
F	Silver / Argent
G	Chrome (Bright Silver)
H	Aluminum / Aluminium

I	Steel
J	Brass / Laiton
K	Gold / L'or
L	Amber / Ambre
M	Transparent Amber / Ambre Transparent
N	Red / Rouge
O	Transparent Red / Rouge Transparent
P	Orange

Q	Yellow / Jaune
R	Tan
S	Brown / Brun
T	Lt. Blue / Bleu Clair
U	Med. Blue / Bleu Moyenne
V	Dark Blue / Bleu Foncé
W	Transparent Blue / Bleu Transparent
X	Lt. Green / Vert Clair

Y	Dark Green / Vert Foncé
Z	Gray / Gris
AA	Purple / Pourpre
IC	Interior Color / Couleur Intérieure
BC	Body Color / Couleur Carrosserie
▲	Semi-Gloss / Semi-Glacé
△	Gloss / Glacé
▲	Metallic / Métallique

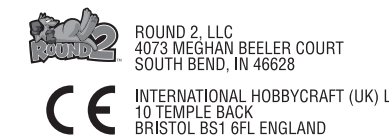

round2models.com

This vehicle body is approved by TOYOTA MOTOR CORPORATION. AMT and design and ROUND 2 and design are registered trademarks of Round 2, LLC. ©2018 Round 2, LLC, South Bend, IN 46628 USA. Product made in the USA. Packaging materials made in China. All rights reserved. / Ce véhicule est homologué par TOYOTA MOTOR CORPORATION. AMT et design et ROUND 2 et le design sont des marques déposées de Round 2, LLC. © 2018 Round 2, LLC, South Bend, IN 46628 États-Unis. Produit fabriqué aux États-Unis. Matériaux d'emballage fabriqués en Chine. Tous les droits sont réservés.

7

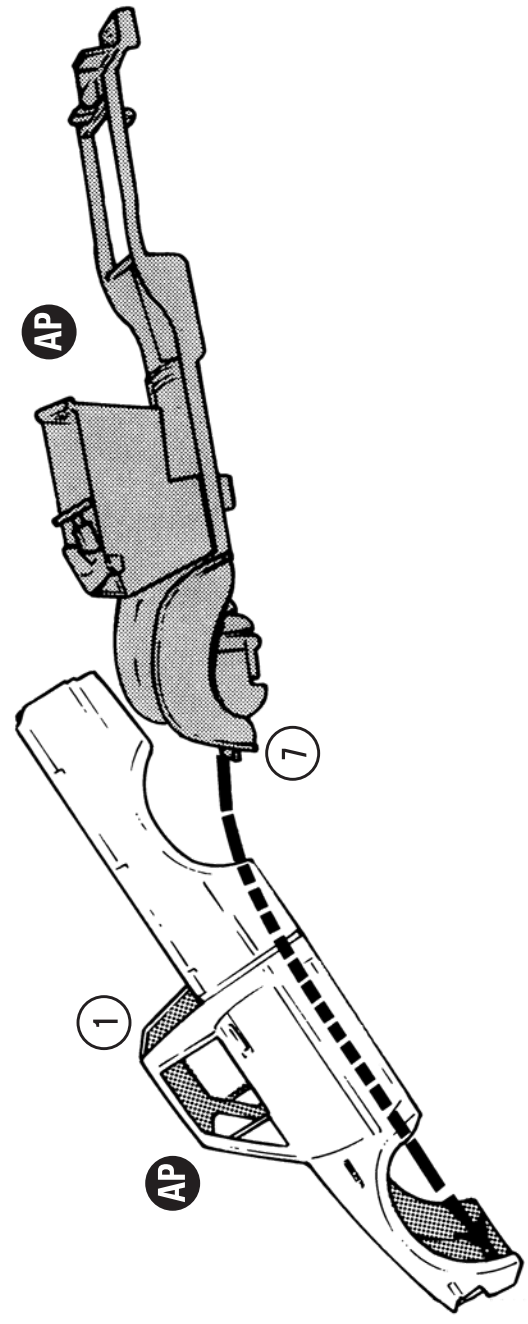

8

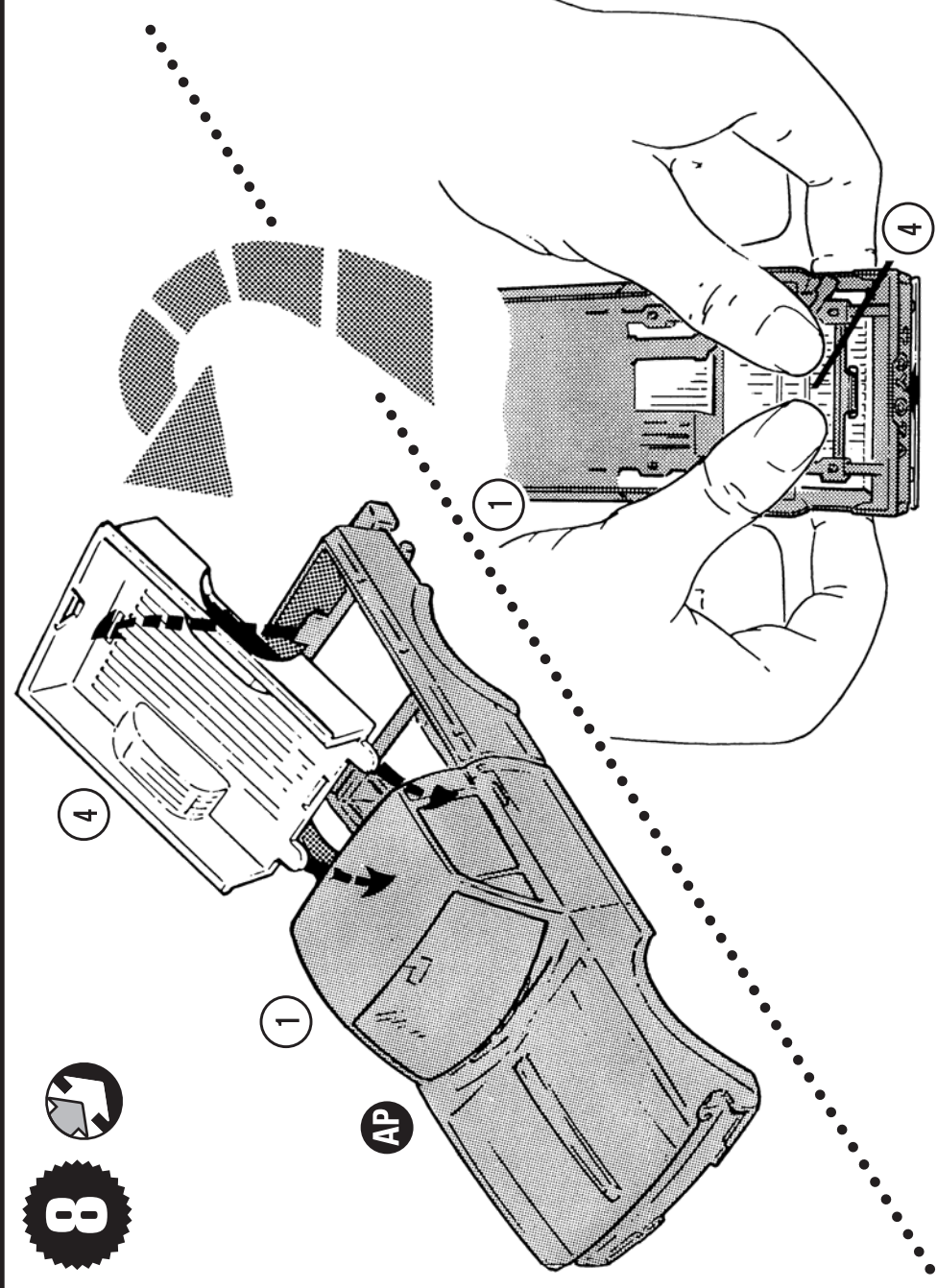

9

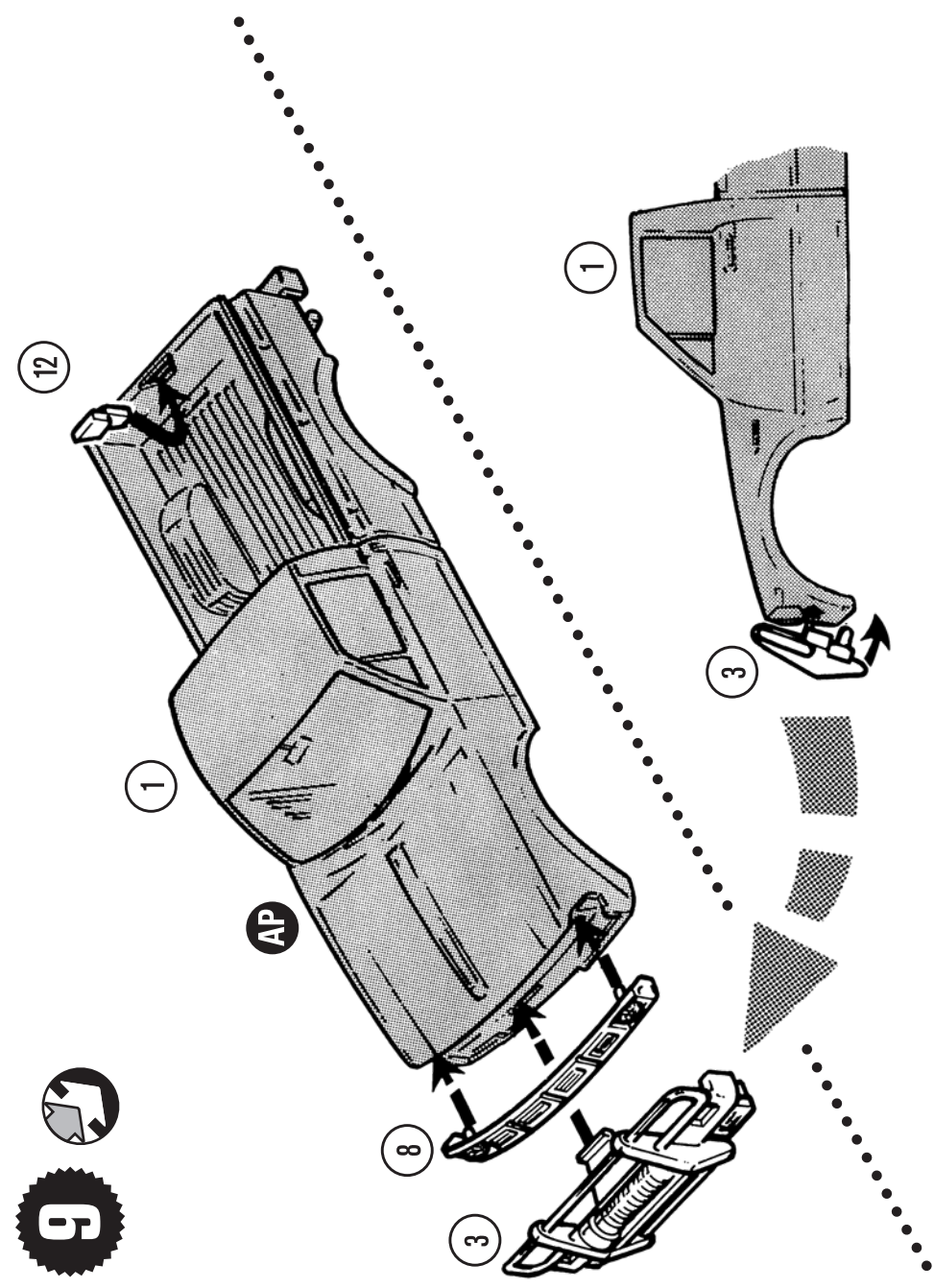

10



1

4X

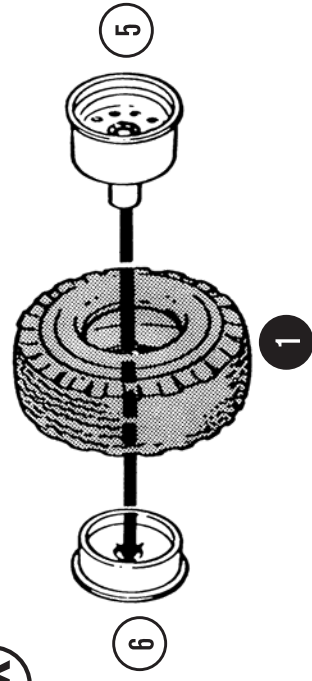

2

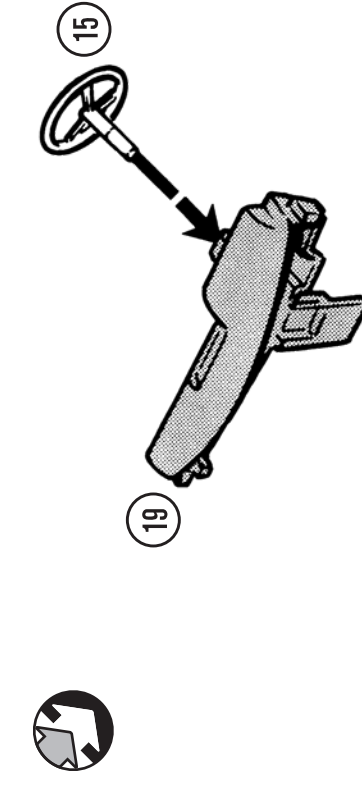

3

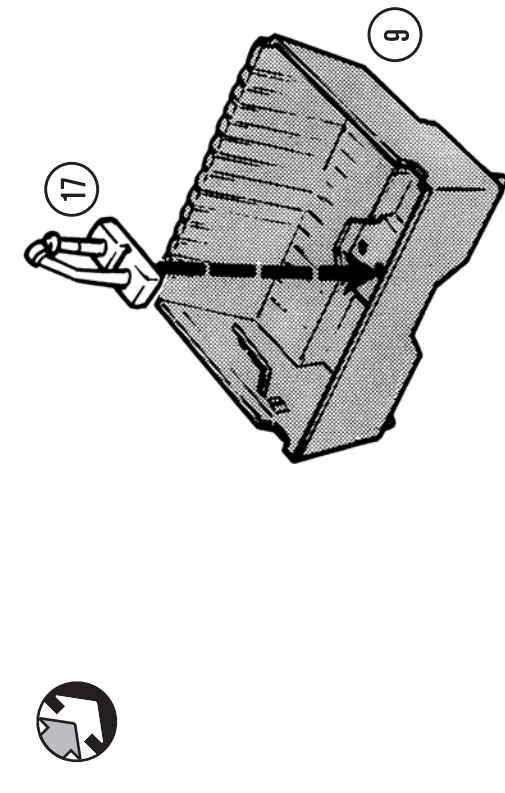

4

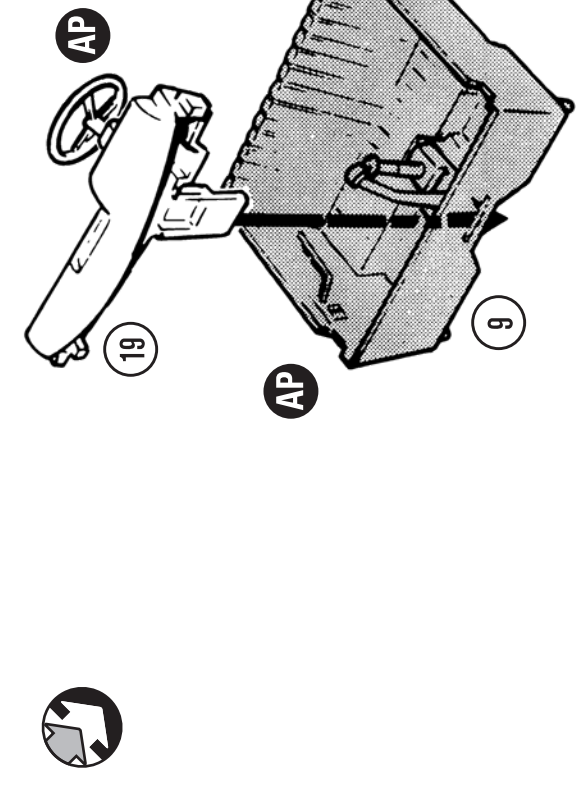

5

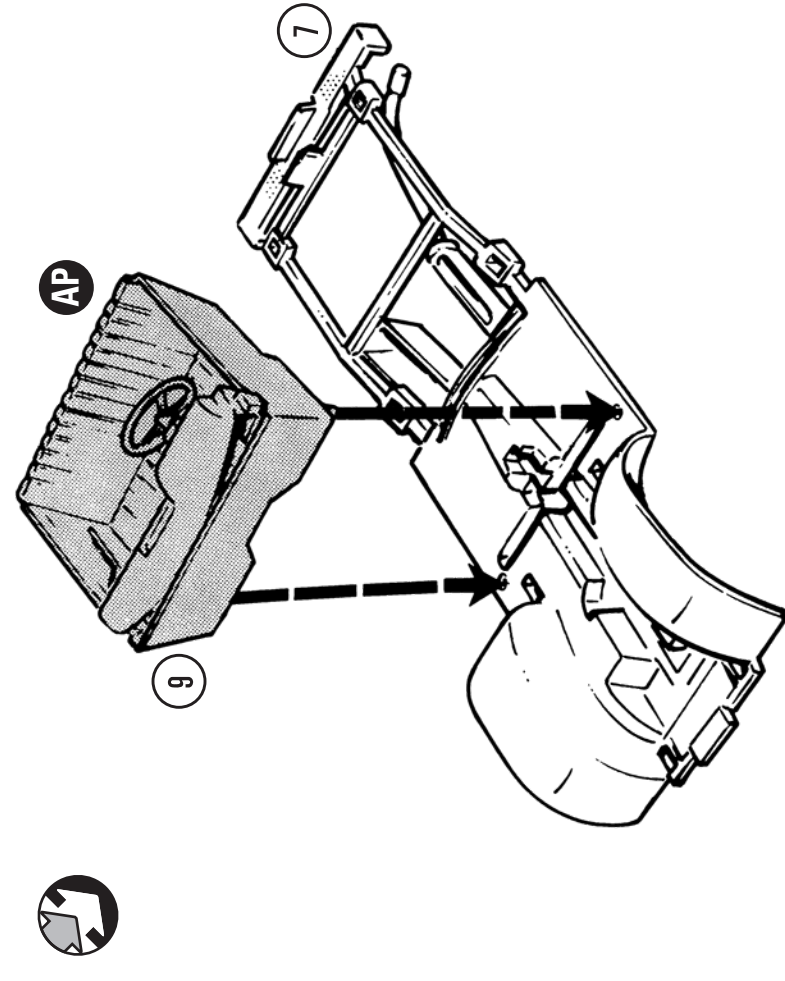

6

