

6. FINAL ASSEMBLY

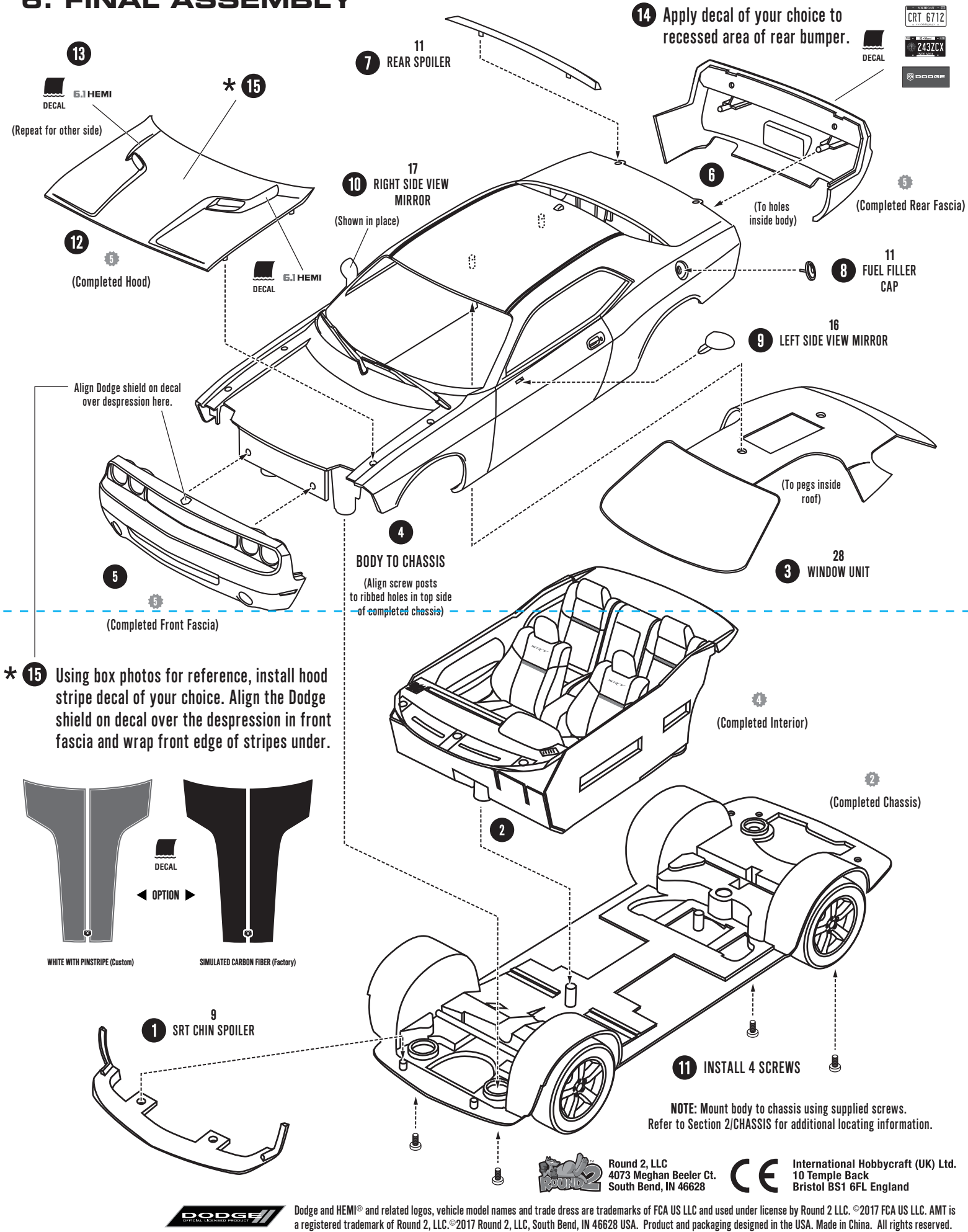

A1075-200

2008 DODGE CHALLENGER SRT8 1/25 SCALE MODEL KIT



READ THIS BEFORE YOU BEGIN

- Carefully study and understand the entire instruction sheet before removing any parts from the trees
- Compare the parts in the box to the instruction sheet to be sure all parts are present and accounted for
- Use clippers or hobby knife to remove parts from the trees - DO NOT twist or bend parts off the trees
- Sand or trim away excess and flash and parting lines from parts before assembling
- As you proceed "TEST FIT" the parts to insure proper location and alignment before cementing
- Sub-assemblies should be painted before other parts are attached
- Use only paints and cements which are specifically formulated for styrene
- Use cement sparingly or a sloppy job may result

! FOLLOW ASSEMBLY SEQUENCE AS SHOWN AND READ ALL NOTES VERY CAREFULLY

PAINTING TIPS: Use a solution of mild soap and water to wash parts thoroughly, to remove any dirt or oily residue. Dry parts with a soft towel, then allow them to fully air-dry. Keep your hands and working area clean and dry when assembling your model kit.

Apply a coat of "primer" prior to painting. Glue joints may then be filled and sanded. Use only filler putty designed for plastic. Test filler on some scrap plastic before applying to your model kit. A tack rag may be used to remove any lint or sanding dust before painting. Paints should be applied evenly in several thin layers rather than one heavy coat. Each layer should be allowed to thoroughly dry before the next is applied. Each coat may be "wet sanded" using slightly damp minimum #1200 sandpaper. Be careful not to remove molded details while sanding. Use frosted tape to mask areas you do not want painted. Remove tape when paint is dry to the touch. Paint lightest colors first. Use a fine brush to touch up edges.

VISIT THE "WORKBENCH" AT www.round2models.com FOR COMPLETE DETAILS ON PAINTING THE 2008 DODGE CHALLENGER SRT8!

1. WHEELS & TIRES

1 Carefully trim center cores from tire along the four joining points.

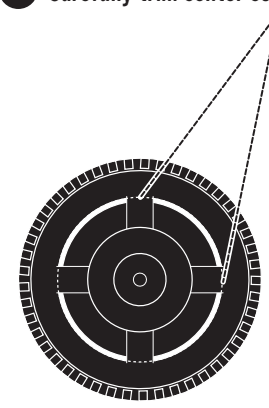

(Vinyl Tire)

2 Repeat for remaining 3 tires.

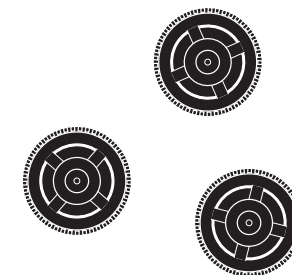

3 Stretch tire over wheel making sure it is fully seated.

NOTE: To make the tires easier to stretch, run them under very warm water for 30-60 seconds. BE CAREFUL NOT TO BURN YOUR HANDS.

24 SRT WHEEL (Chrome)

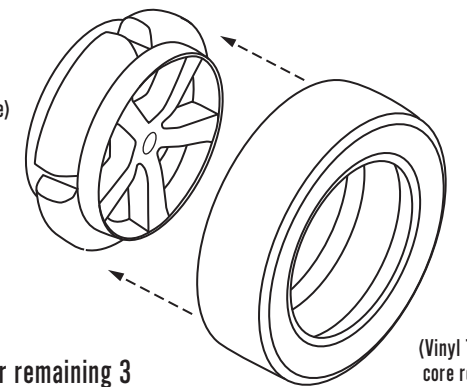

(Vinyl Tire with core removed)

4 Repeat for remaining 3 wheels and tires.

SYMBOLS

1 Assembly Sequence Apply Decal

49 Part Number **3** Completed Assembly

RECOMMENDED PAINT COLORS

Aluminum	Silver	Flat Black
Gloss Black	Semi-Gloss Black	Red
Amber	White	

REFER TO BOX ART PHOTOS FOR PAINTING DETAILS

DECALS: See back of decal sheet for application instructions. Many of the very small decals in this kit have been included in duplicate to serve as backups, should any get lost or otherwise compromised during application.

DECALS MUST BE APPLIED TO CERTAIN PARTS PRIOR TO ASSEMBLY. SEE SECTION 3 FOR FULL DETAILS.



Dodge and HEMI® and related logos, vehicle model names and trade dress are trademarks of FCA US LLC and used under license by Round 2 LLC. ©2017 FCA US LLC. AMT is a registered trademark of Round 2, LLC. ©2017 Round 2, LLC, South Bend, IN 46628 USA. Product and packaging designed in the USA. Made in China. All rights reserved.

Round 2, LLC
4073 Meghan Beeler Ct.
South Bend, IN 46628

International Hobbycraft (UK) Ltd.
10 Temple Back
Bristol BS1 6FL England

2. CHASSIS

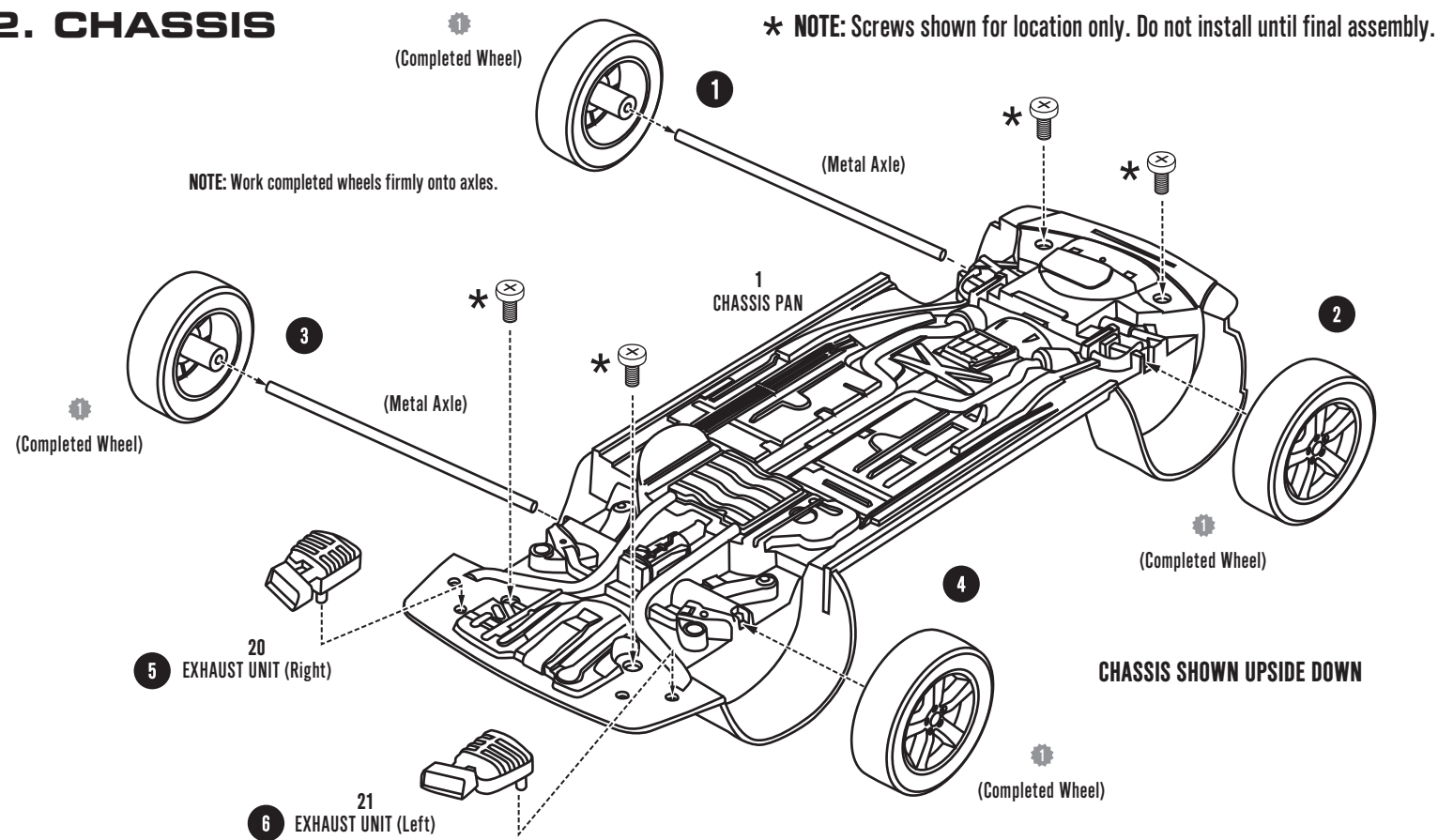

3. DETAILING DECALS

DECALS: See back of decal sheet for application instructions. Many of the very small decals have been included in duplicate to serve as backups, should any get lost or damaged during application.



IMPORTANT: Apply decals to seats, dashboard and steering wheel BEFORE assembling parts in Section 4/INTERIOR. BE SURE TO PAINT THE DESIRED PARTS FIRST AND ALLOW THEM TO DRY FULLY BEFORE APPLYING DECALS.

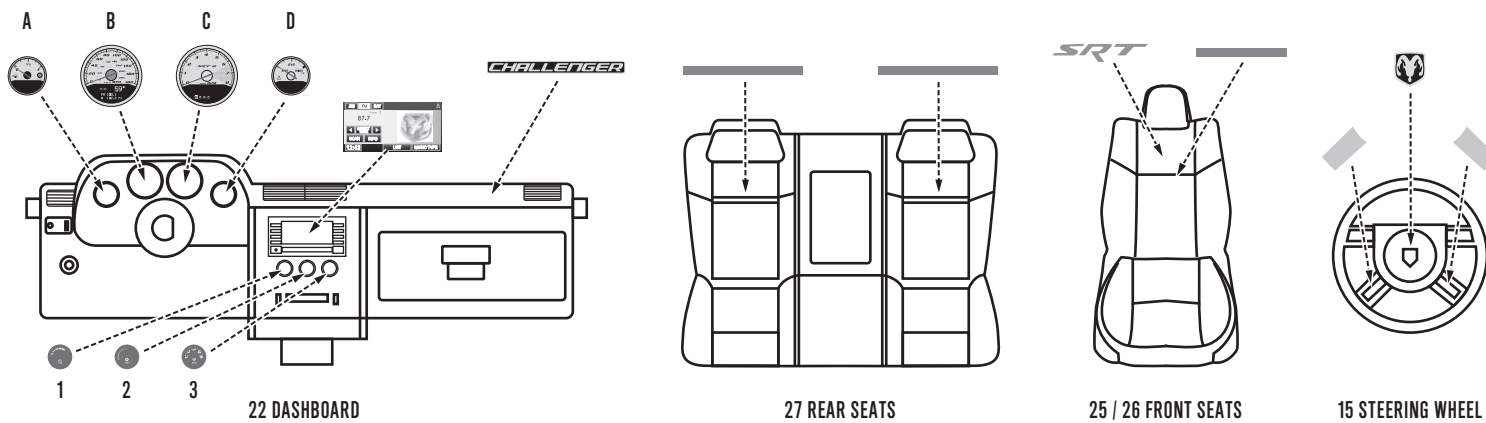

Due to small size, it is suggested these parts have their detailing decals applied prior to assembly.

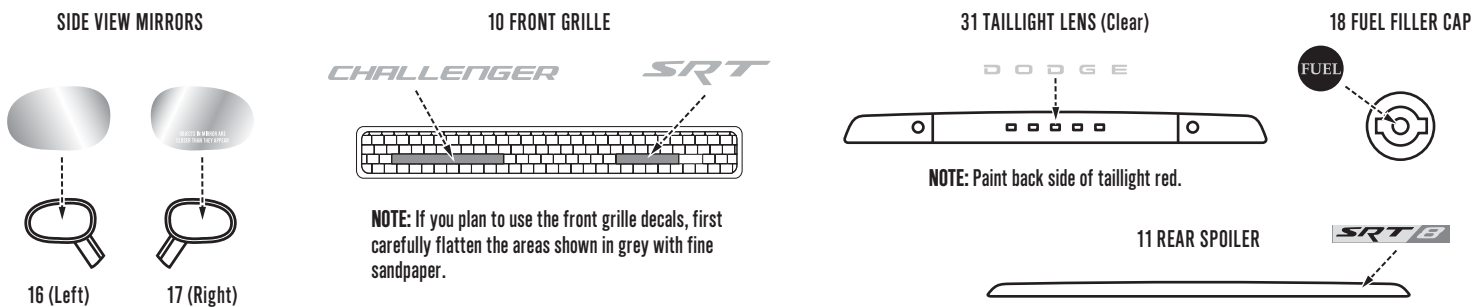

4. INTERIOR

IMPORTANT: Apply decals to seats, dashboard and steering wheel as shown in SECTION 3 BEFORE assembling parts.

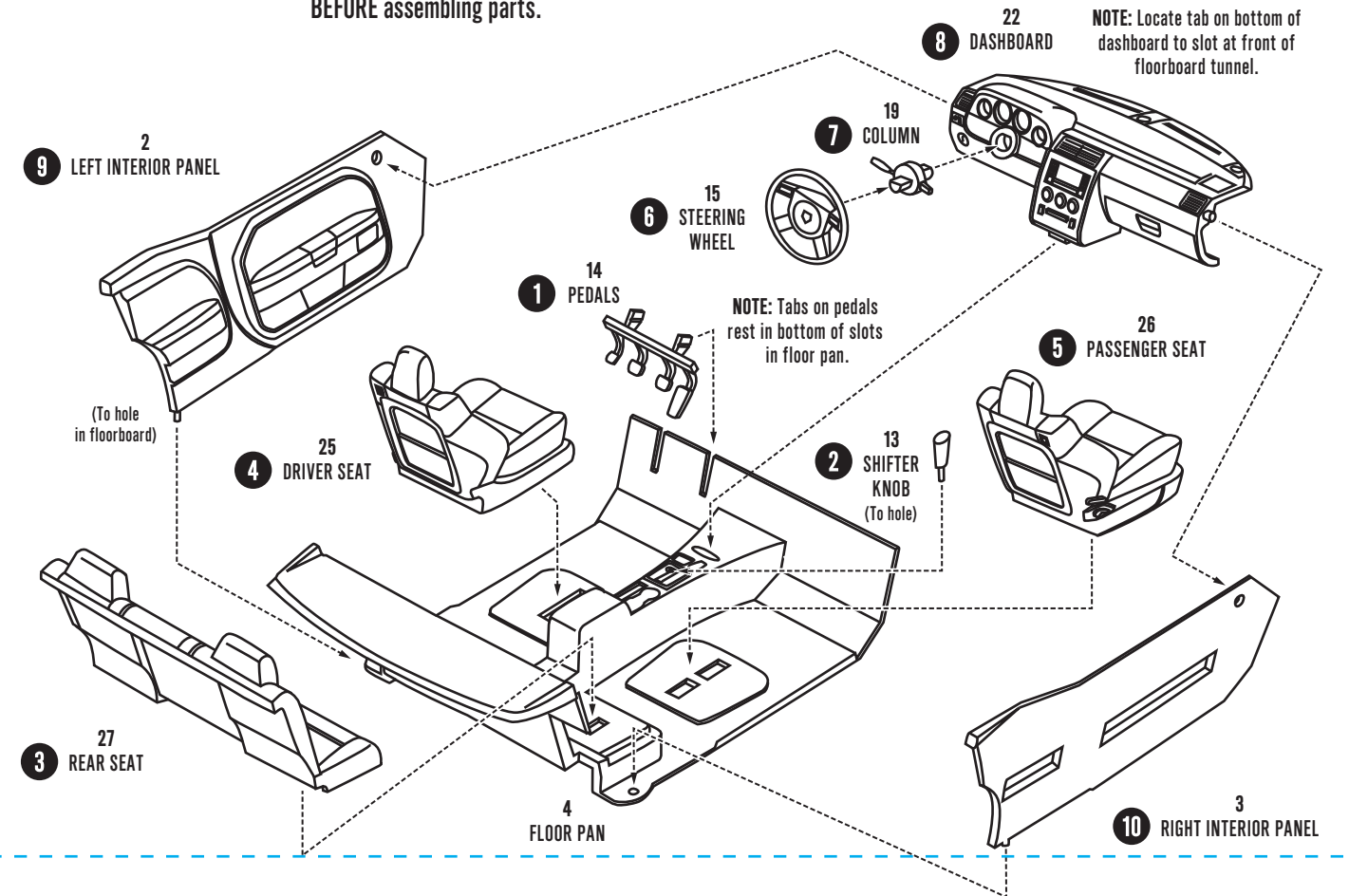

5. BODY SUB-ASSEMBLIES

