

1: ENGINE

A Paint the parts shown here prior to assembly.

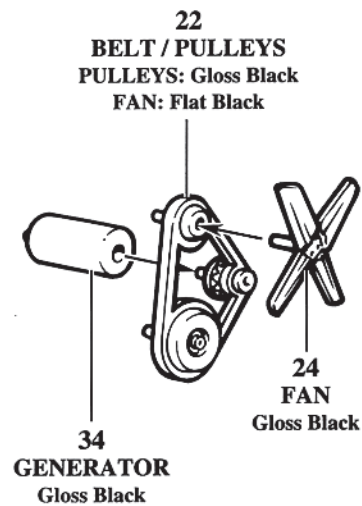

B Assemble and then paint Chevrolet Gray (medium gloss gray) as a unit. Apply small yellow "Thriftmaster" DECAL after paint has fully dried.

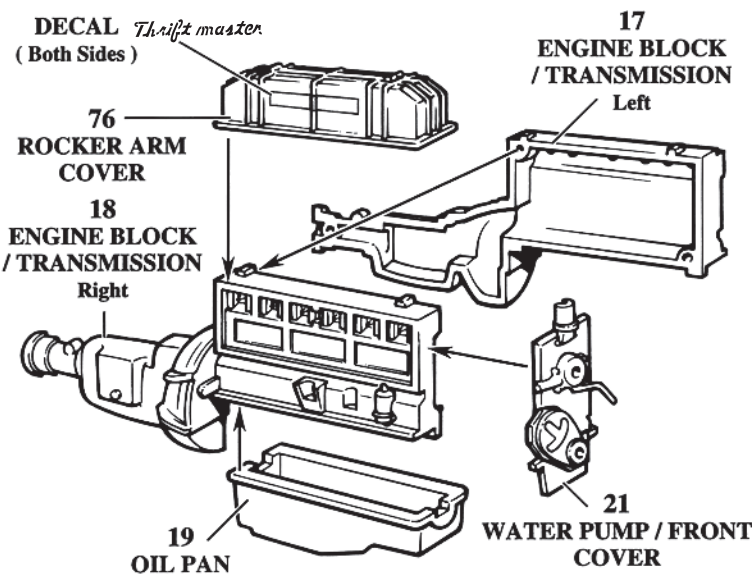

C Paint the parts shown here prior to assembly.

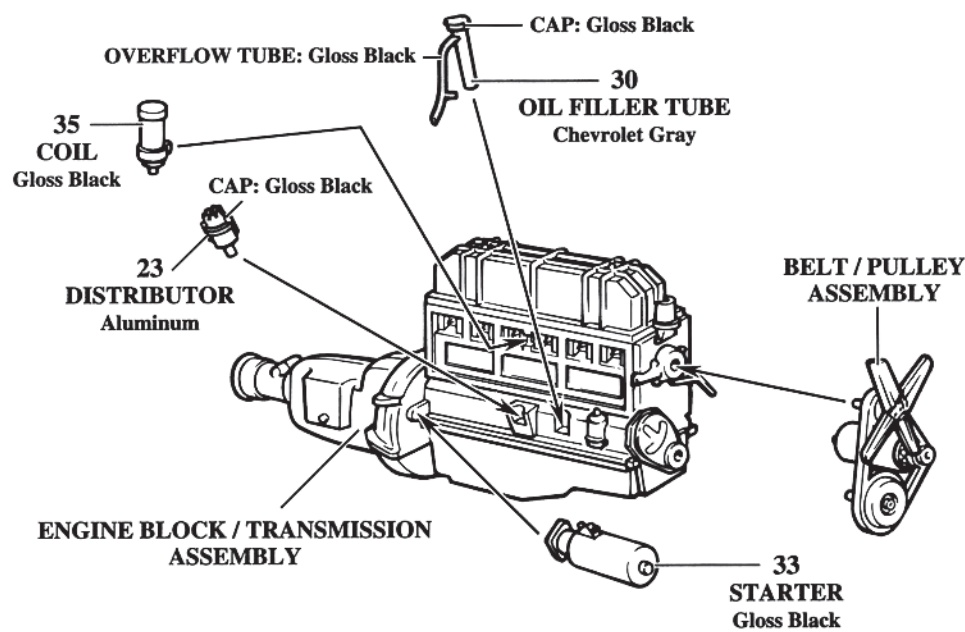

D Paint the parts shown here prior to assembly.

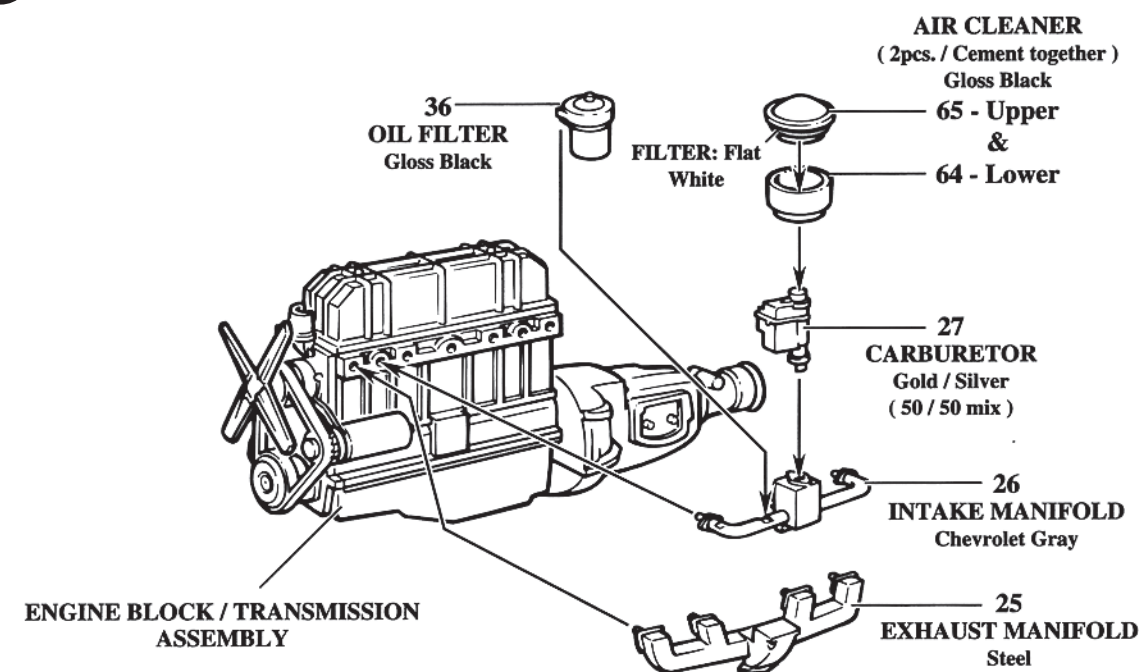

2: WHEELS

Paint the WHEELS prior to assembly. Assemble 4 sets. Valve stems must be REMOVED if you use the TRIM RINGS. NOTE: An outer FRONT wheel is shown - REAR wheels do not have center hubs.

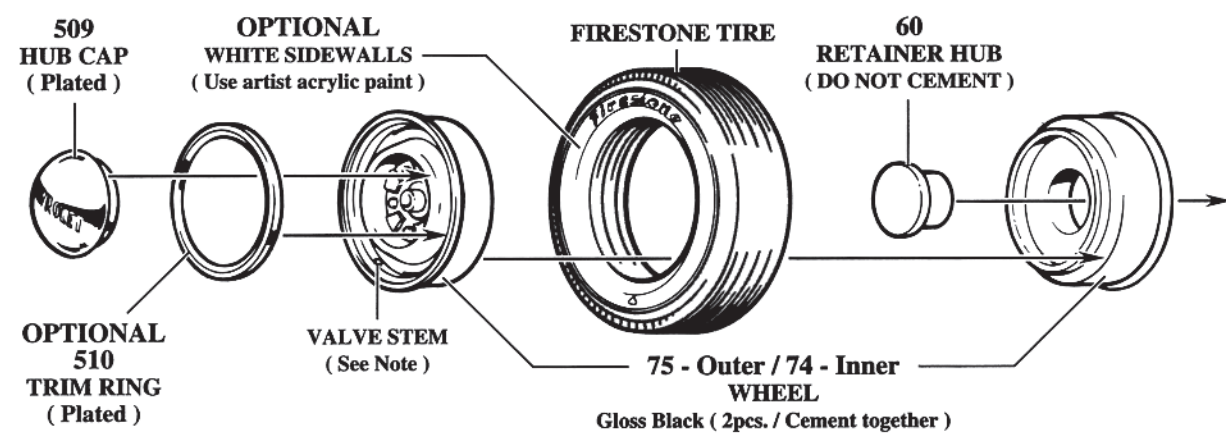

3: CHASSIS

A Paint the parts shown here, except the FRONT and REAR SHOCKS, gloss black prior to assembly. Paint all SHOCKS dark blue.

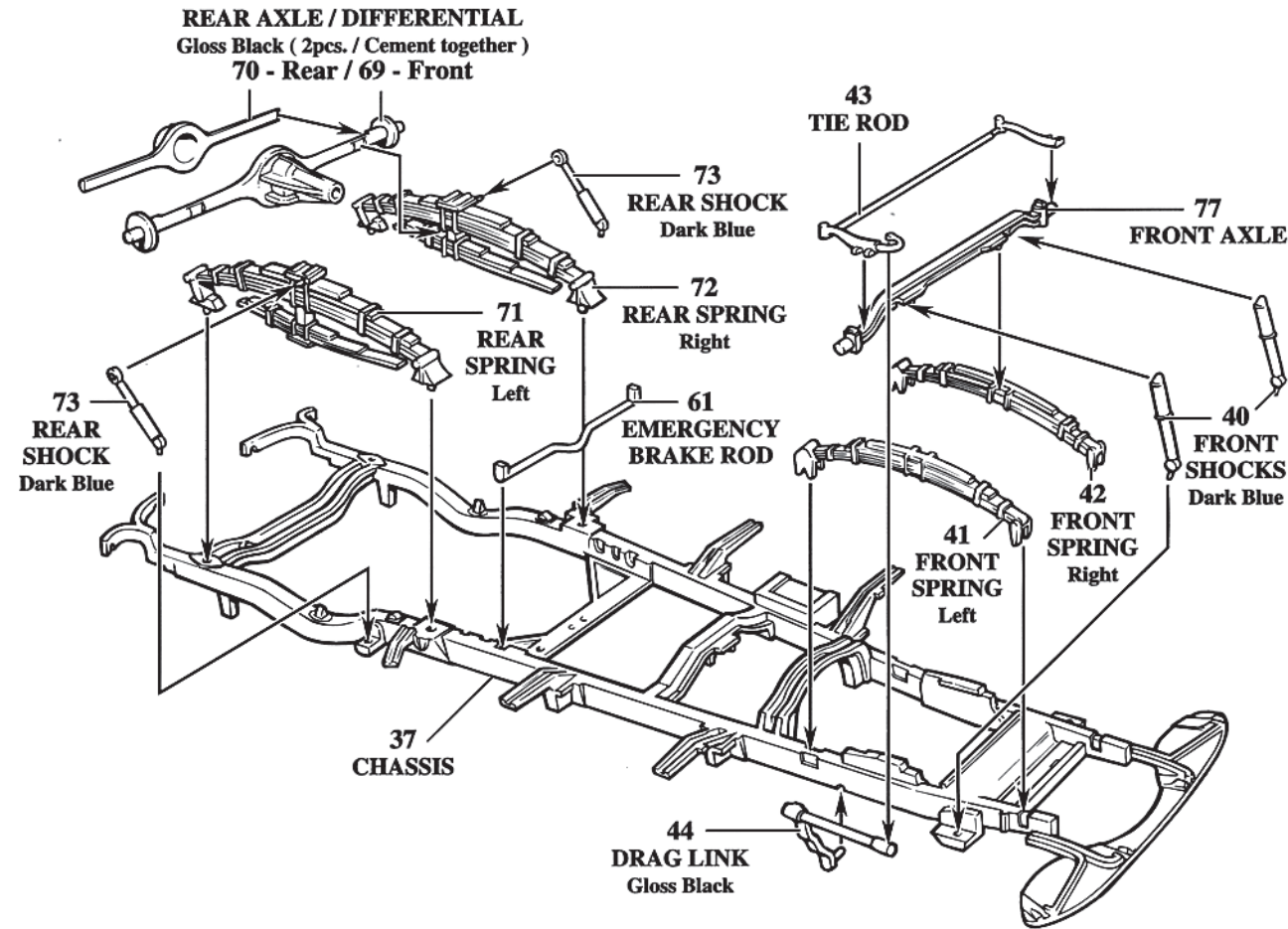

B Paint the parts shown here prior to assembly.

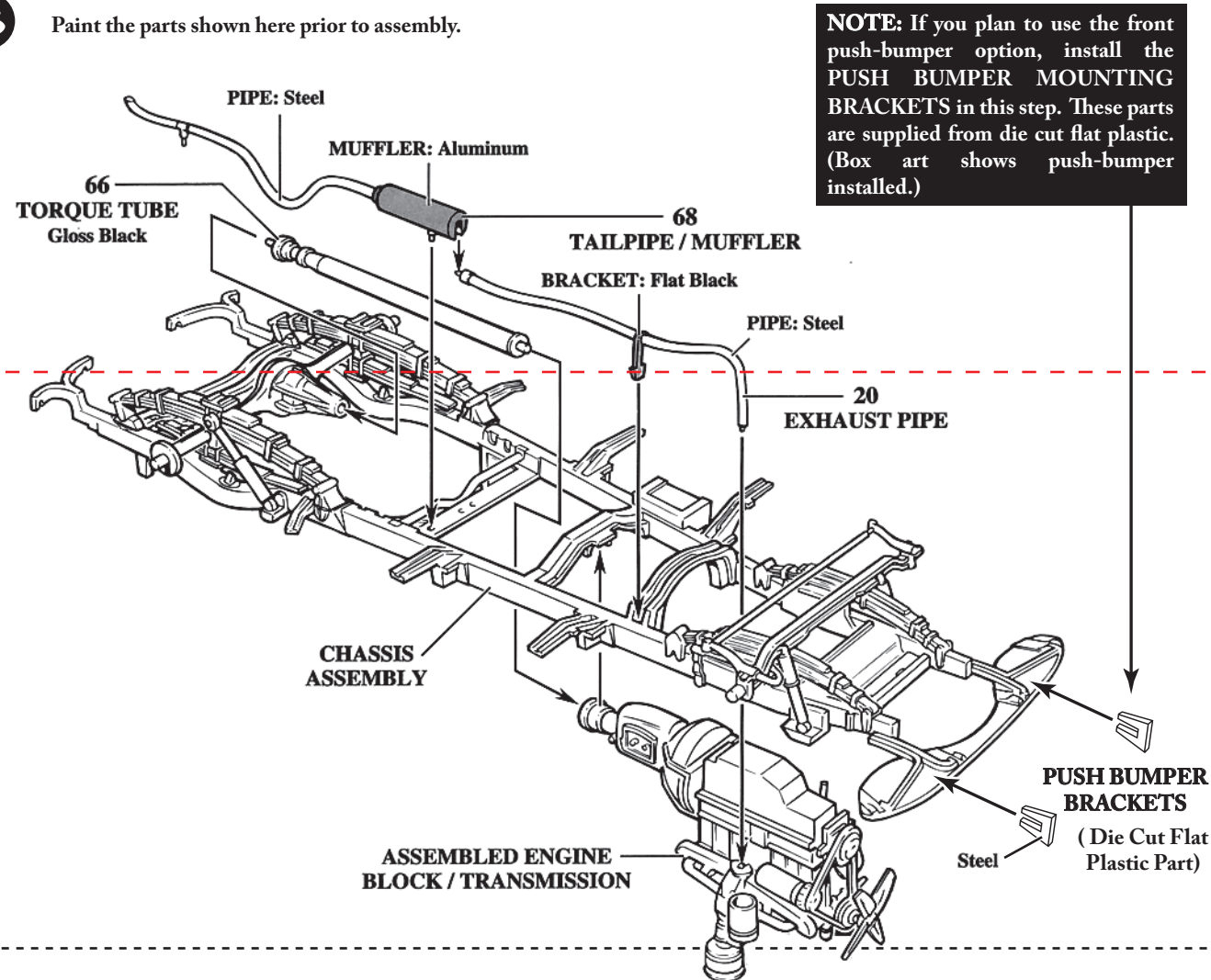

NOTE: If you plan to use the front push-bumper option, install the PUSH BUMPER MOUNTING BRACKETS in this step. These parts are supplied from die cut flat plastic. (Box art shows push-bumper installed.)

C Paint the parts shown here prior to assembly.

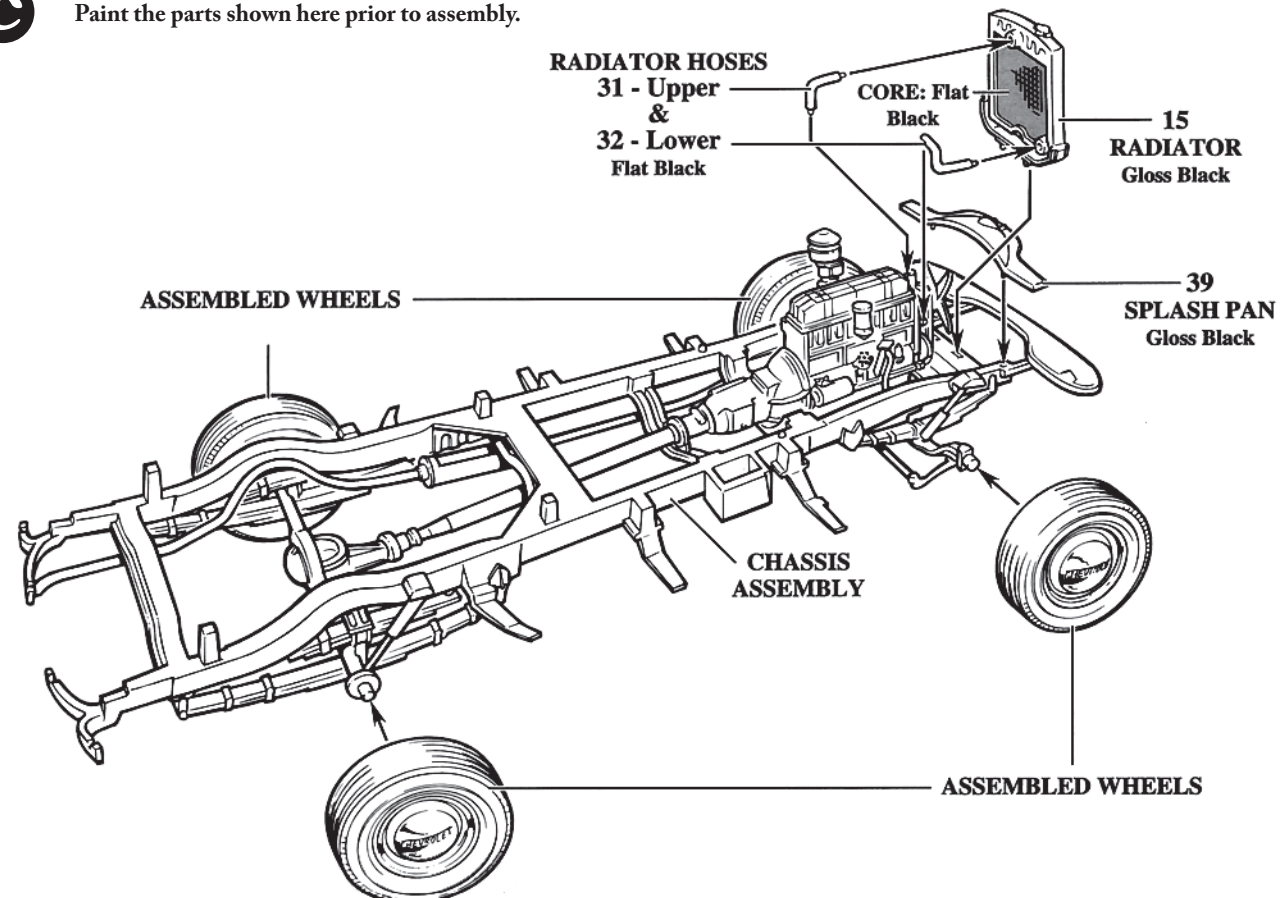

4: INTERIOR

A Paint the parts shown here prior to assembly. NOTE: All pedals should be painted flat black with gloss black arms. Use flat paints for the "cloth" surfaces and gloss paint for metal. Cloth sections maybe painted tan, gray or black.

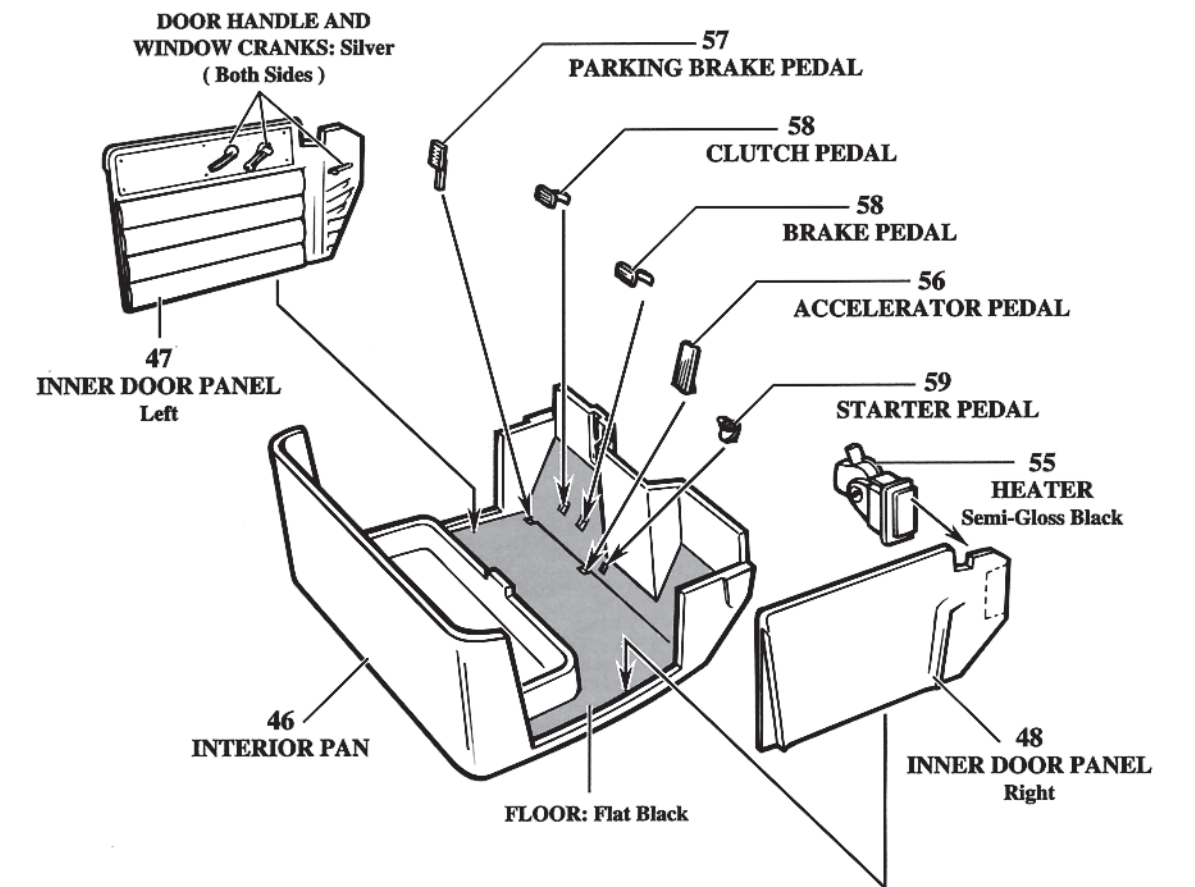

B Paint the parts shown here prior to assembly. Do NOT cement the BENCH SEAT BACK in place, so that it can fold forward.

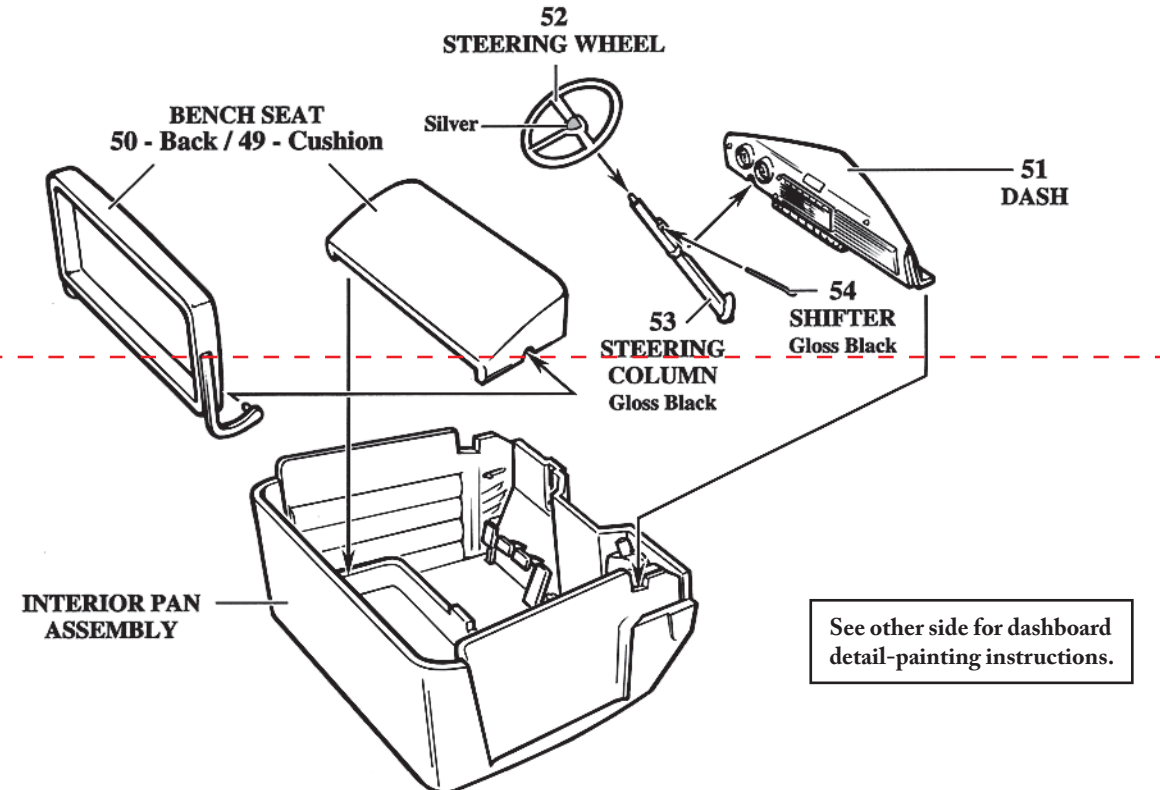

See other side for dashboard detail-painting instructions.

5: PICKUP BOX

Assemble the parts as shown and paint to match the CAB. See other side for further painting information. Paint the BOX FLOOR after the unit has thoroughly dried.

